

The BX (Wireless) Series latching relays are a combination of load shedding functions combined into a single device. The BX (Wireless) Series with wireless controller is available with 100A or 200A latching relays. The relays can be controlled by dry contact input capable of emulating NO or NC relays and contactors. The BX (Wireless) Series also includes wireless load lockout on air-cooled or liquid cooled generators & wireless under-frequency load management for use with any air cooled generator.

BX (Wireless) Series Latching Control Board

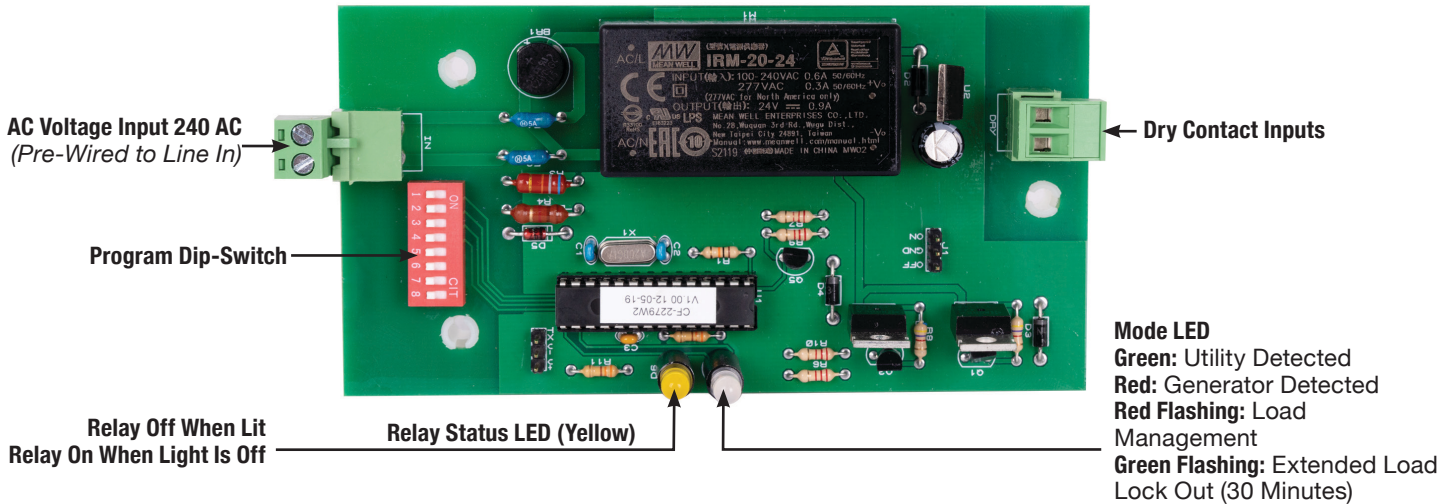

Dry Contact Control of Relay Mode 1-3

Mode 1 Normally OPEN Contactor Emulator: When dry contact inputs are open, the relay is turned off. When dry contact inputs are closed, the relay is turned on.

Mode 2 Normally Open Contactor Emulator With 5 Minute Lockout: Functions are the same as mode 1 except there is a 5 minute delay after dry contacts inputs are closed before the relay will be toggled to the on position.

Mode 3 Normally Closed Relay Emulator: When dry contact input pins are open, relay is turned on. When dry contact input pins close relay is turned off.

Generator Load-Lockout Mode 4

At power-up the module will begin analyzing the AC sine wave for about 90 seconds. When utility power is detected, mode LED will illuminate green and the load will be restored after a 2-3 minute delay. Relay status LED will turn off indicating the load is restored. After a power outage, the module will disconnect the load, when generator power is detected, mode LED will illuminate red, and the relay status LED will be on, the load will remain disconnected. The module will continue to analyze the AC power source until utility voltage is detected. After detecting utility voltage, mode LED will turn green, after a 3-5 minute delay, the load will be restored and relay status LED will go off indicating the load is restored. The module will now enter sleep mode and will remain inactive until the next power outage.

Generator Load-Management Mode With Under-Frequency Detection Mode 5

There are two settings designed to accommodate most air-cooled generators. Mode "A" is designed to give more tolerance and longer delay (reactive loads) times where mode "B" is set for a lower threshold for generators that maintain a tighter frequency range and resistive loads.

At power-up the module will begin analyzing the AC sine wave for about 90 seconds. When utility power is detected, mode LED will illuminate green and the load will be restored after a 3-6 minute delay based on the priority setting chosen. Relay status LED will turn off indicating the load is restored. After a power outage, the module will disconnect the load, when generator power is detected, mode LED will illuminate red, and the load will be restored after a 3-6 minute delay dependent on the priority selected. The mode LED will flash red indicating "load shedding mode", and the relay status LED will turn off indicating the load has been turned on. In the event of an overload condition, the load will be disconnected (relay status LED on) and the load will remain disconnected for 3-6 minutes dependent on the priority selected. After the load-shed delay, if frequency is stable, the load will be restored (relay status LED off) and the cycle continues until utility voltage is detected. In the event, an overload condition is detected within 2 seconds of restoring a load, that load will be turned off and locked out for an extended period of 30 minutes indicated by a flashing green mode LED. After utility returns, mode LED will turn green, after a 3-6 minute delay, the load will be restored and relay-LED will extinguish indicating the load is connected. The module will now enter sleep mode and will remain inactive until the next power outage.

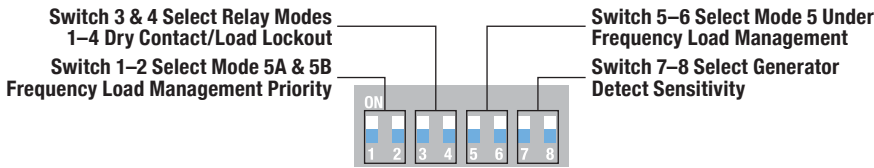

Important note: Dip-switch controls do not illuminate or change color when state is changed. The switches are displayed in black (for on) and blue (for off) state for illustration purposes only.

Dry Contact Relay Control Modes 1-3 & Load Lock-Out On Generator Mode 4: Use Switches 3 & 4 for Modes 1-4

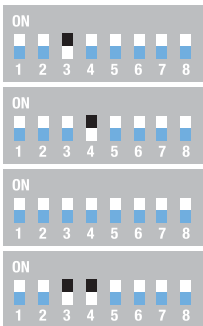

Mode 1 - Normally Open Contactor Emulator: When dry contact inputs open, relay is toggled off. When dry contact inputs are closed, relay is toggled on.

Mode 2 - Normally Open Contactor Emulator With 5 Minute Lockout: Functions are identical to mode 1 with the following exception. There is a 5 minute delay before relay closes after dry contact inputs are closed.

Mode 3 - Normally Closed Relay Emulator: When dry contact inputs open, relay is toggled on. When dry contact inputs are closed, relay is toggled off.

Mode 4 - Load Lock-Out When Generator Source Is Detected: Locks the load out on generator power-up until utility power is restored. Load will be restored in 3-5 minutes after transfer back to utility voltage. (3 = on, 4 = on)

Under-Frequency Load Management On Generator Power Mode 5A & 5B: Use Switches 3, 4, 5, 6 for Modes 1-4

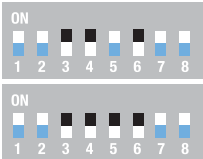

Mode 5 - Under-Frequency Load Management Mode A: Restores load on generator after power-up priority delay selected. Removes load during under-frequency event, restores load based on priority selected. (5 = off, 6 = on)

Mode 5 - Under-Frequency Load Management Mode B: Restores load on generator after power-up priority delay selected. Removes load during under-frequency event, restores load based on priority selected. (5 = on, 6 = on)

Priority Settings for Modes 5A & 5B

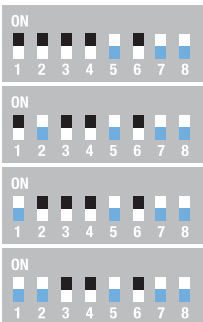

Mode 5 - Load Priority One (Mode A or B): Restores load under generator power after approximately 3 minute delay. Restores load after under-frequency event after 3 minutes. (1 = on, 2 = on)

Mode 5 - Load Priority Two (Mode A or B): Restores load under generator power after approximately 4 minute delay. Restores load after under-frequency event after 4 minutes. (1 = on, 2 = off)

Mode 5 - Load Priority Three (Mode A or B): Restores load under generator power after approximately 5 minute delay. Restores load after under-frequency event after 5 minutes. (1 = off, 2 = on)

Mode 5 - Load Priority Four (Mode A or B): Restores load under generator power after approximately 6 minute delay. Restores load after under-frequency event after 6 minutes. (1 = off, 2 = off)

Service Adjustments

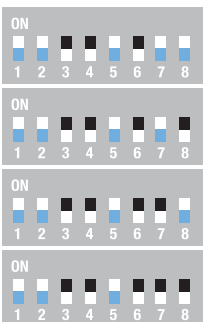

Utility/Generator Sensitivity Settings:
Modes 4 & 5 only normal default settings (7 = off, 8 = off)

Utility/Generator Sensitivity Settings:
Modes 4 & 5 only high setting (7 = off, 8 = on)

Utility/Generator Sensitivity Settings:
Modes 4 & 5 only medium setting (7 = on, 8 = off)

Utility/Generator Detect Settings:
Modes 4 & 5 only low setting (7 = on, 8 = on)

120VAC Input Normally Closed Relay Emulator

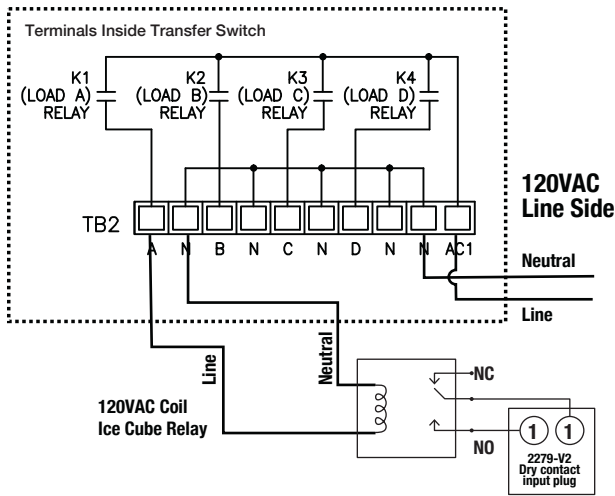

Kohler® Load Shedding Controller Mode 3 = Normally Closed Relay Emulator

Relay will be controlled by a 120VAC coil voltage ice cube relay. 0 volts AC from A & N will turn load on. 120VAC from A & N will turn load off.

Dry Contact Input Normally Open Contactor Emulator

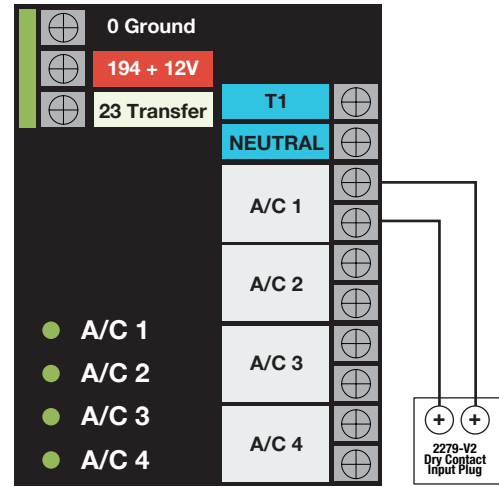

120VAC Coil Ice Cube Relay

Generac® Load Shedding Controller Mode 1 = Normally Closed Contactor Emulator

Relay will be controlled with a dry contact input from A/C 1. When A/C 1 pins are closed load will turn on. When AC pins are open load will turn off.

Load Dropping

Dry Contact Input Normally Open Contactor Emulator With 5 Minute Delay

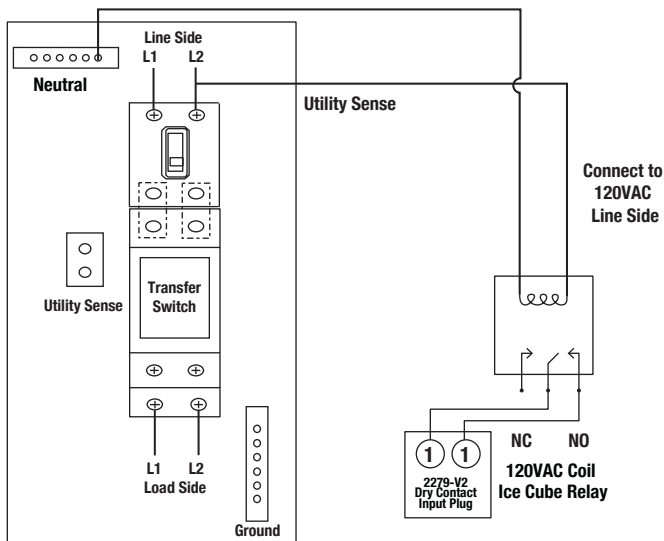

Mode 2 On = Normally Open Contactor Emulator With 5 Minute Lockout

On power up the relay will open and remain open until dry contacts are closed for a period of 5 minutes. After the lock out delay the relay will toggle closed. The relay will toggle off whenever voltage is lost at dry contact inputs and will require contacts to be closed for 5 minutes before load is restored.

Dry Contact Input Normally Closed Emulator

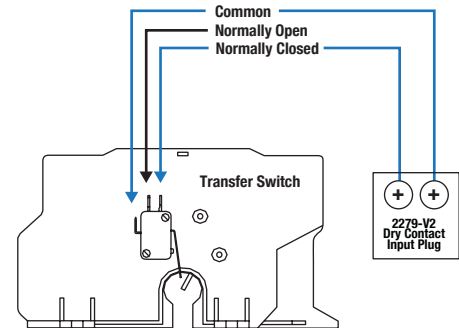

Mode 3 = Normally Closed Relay Emulator

Relay will be toggled on and off with dry contact inputs. When dry contact inputs are open, the relay will toggle on. When dry contact inputs are closed, relay will toggle off.

The BX Wireless comes preset to work with most generator and utility systems. However, because there are always circumstances outside of normal, additional settings are available to accommodate most conditions. Please contact technical support for additional information at 703-687-4057.

Control Board Programming Flow Chart

